



T30 HydroSeeder

The FINN T30 HydroSeeder is ideal for entry-level and smaller hydroseeding projects. FINN developed HydroSeeder technology in 1953. We've been the industry leader in quality and innovation ever since. With the FINN T30, you don't have to settle for less than proven and reliable FINN quality for a wide array of the most common hydroseeding applications.

Versatile & Economical. The T30 is FINN's most economical HydroSeeder ever. You can easily manage professional quality seeding, fiber mulching, straw tacking, and much more – all with legendary FINN efficiency and cost effectiveness.

Feature Filled Operation. The FINN T30 HydroSeeder features a durable, 300 gallon capacity steel tank; a hydraulically-driven and reversible mechanical agitator for fast and thorough mixing; simple controls for economical one-man operation;

a FINN-designed centrifugal pump that handles the thickest of slurries with ease; and, fork lift channels and lift ring for easy handling.

All Around Performance. The T30 goes everywhere you need it to go: residences, cemeteries, golf courses, sports fields, office and apartment complexes, parks, and more.

As the world leader for over 70 years in the design and manufacture of innovative, quality equipment for the green industry, FINN Corporation is committed to your complete satisfaction.

Model shown may include optional equipment.

SMARTER WAYS TO WORK

9281 LeSaint Drive • Fairfield, OH 45014-5457 • Phone (513) 874-2818 • Fax (513) 874-2914
Toll Free (800) 543-7166 • Parts (800) 229-8707 • E-mail: sales@finncorp.com
Customer Service/Warranty (888) 382-1966

T30 SKID MOUNT

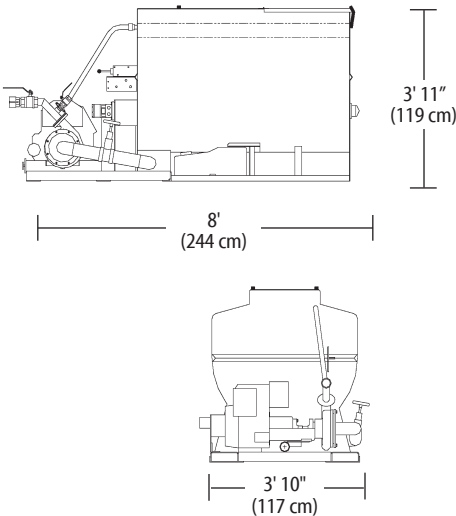

FINN MODEL T30 TECHNICAL SPECIFICATIONS

POWER	Kohler Command 15 hp (11.2 kw), electric start, air cooled gas, oil guard protection
ENGINE SAFETY SYSTEM	Low oil pressure, high water temperature shutoff
TANK SIZE	310 gallon (1,175 liter) liquid capacity, 260 gallon (984 liter) working capacity
FUEL TANK CAPACITY	6.6 gallon (25 liter)
PUMP	Centrifugal 3" x 1 1/2" (7.5 cm x 3.75 cm), 65 GPM @ 60 psi (227 lpm @ 414 kPa), 3/4" (1.9 cm) solid clearance
PUMP DRIVE	Direct drive through electric clutch, pump drive is independent of agitator operation
AGITATION	Mechanical paddle agitation and liquid recirculation
AGITATOR DRIVE	Reversible, variable speed hydraulic motor (0-129 rpm), with control lever at front and rear of unit
DISCHARGE DISTANCE	Up to 70 ft. (23 m) from end of hose
MAX. MATERIAL CAPACITY	500 lbs. (227 kg) granular solids, 100 - 120 lbs. (45 - 55 kg) fiber mulch
NOZZLES	(1) narrow fan, (1) wide fan, (1) long distance
HOSE ATTACHMENT	50' x 1 1/4" semi-rigid polybraid or 50' x 1 1/2" collapsible hose, remote valve
EMPTY WEIGHT	1,050 lbs. (477 kg)
WORKING WEIGHT*	3,900 lbs. (1,769 kg)

*Working weights are approximate and do not include options or stored materials.

FINN Corporation has a policy of continuous product improvement, and reserves the right to change design and specifications without notice.

HydroSeeder® is a registered trademark of the FINN Corporation.